

NITTOSEIKO

Signal spindle screw driving machine

FEEDMAT FM series

F A S T E N I N G I N N O V A T I O N
f o r T H E F U T U R E

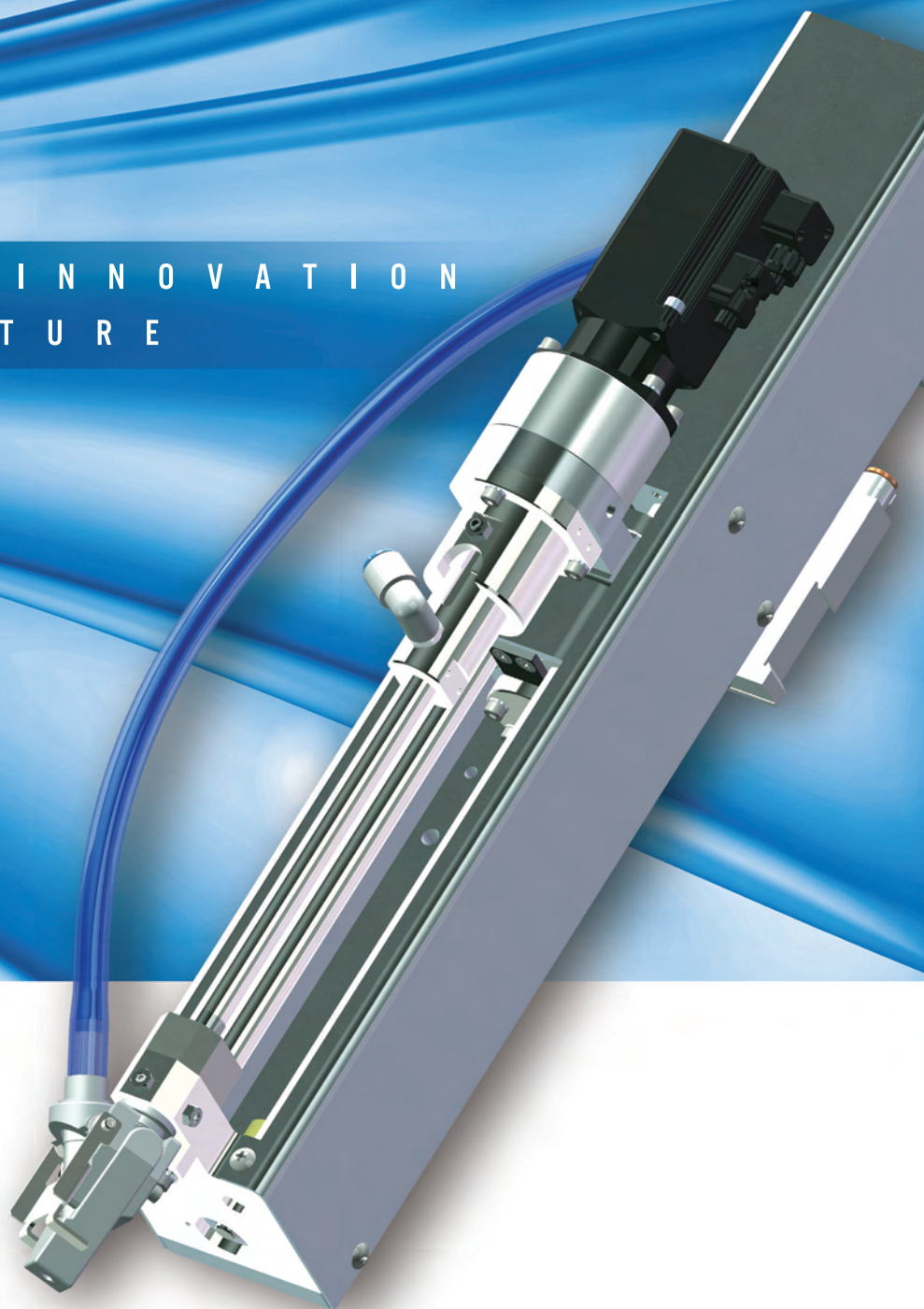

Easy install on robots, Workcells and lines

Our FEEDMAT FM Series boasts a wealth of proven results for use as robot-mounted screw driving units and automated line units.

Their compact size and light weight provide easy installation and handling, making them extremely effective for automation and reducing labor.

We provide a complete lineup of models to match screw size and work modes.

Feature 01

Turn Key Solution

The package includes all components to feed and drive a screw, allowing immediate use after installation. Near zero integration cost and time. (Standard set contents vary depending on the type.)

Feature 02

Equipped with Nitto Seiko Screw Driving Motors

Equipped with our KX drivers (AC servo screw driving motors) and NX drivers with torque display.

Feature 03

Thrust force control

This function performs ideal screw-driving by using a preset optimal thrust force to match the screw type and workpiece.

Feature 04

Adapt to EtherNet/IP™ with RC77 controller

It's possible to use the EtherNet/IP™ and DeviceNet™ in addition to CC-Link and Ethernet.

Feature 05

Lineup Covering All from M1.7 to M8

We provide a wide variety of types with varying screw sizes, driver types and screw holding methods (chuck claws and vacuum suction) to match all of your needs.

We can also handle special requests for machines for all applications such as nut and stud bolt tightening.

Model selection chart

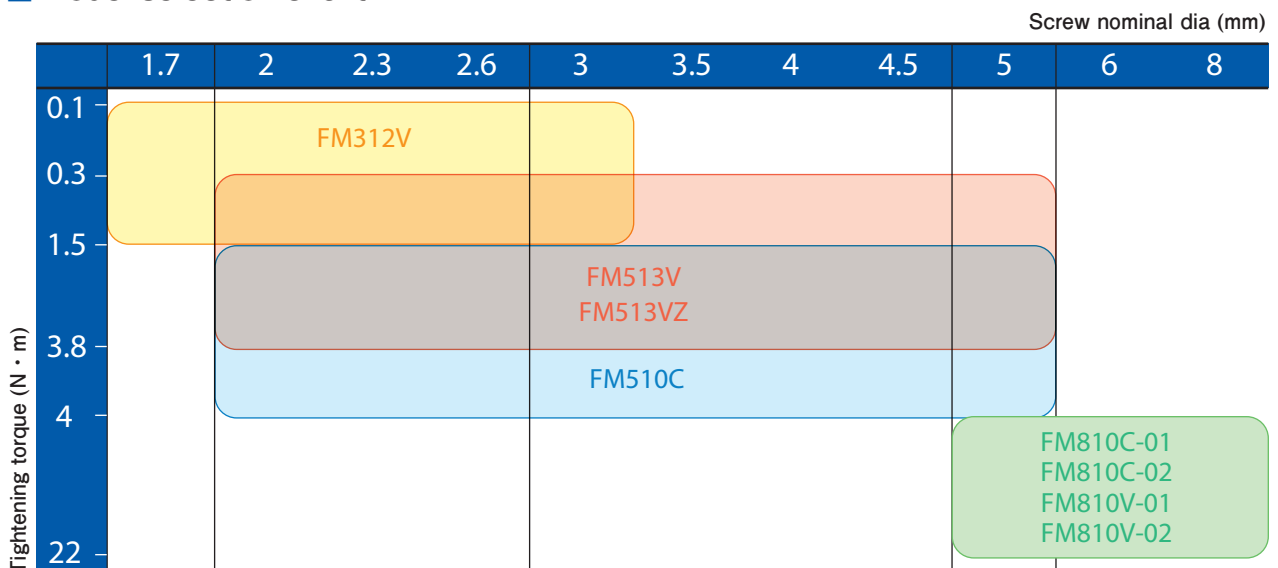

Servo Z-axis

Vacuum type screw driving unit with the thrust force control function. [Type VZ]

Feature

This tool, with thrust force control, provides high-quality screw driving because of optimum thrust force adjustment. Torque and speed are adjusted separately to provide optimal screw driving to match not only characteristics such as material properties, hardness, and thickness, but also working application and location. In comparison with the pneumatic Z-axis, the compact size provides low air consumption and easy maintenance.

Specifications of tool unit

[] : Optional

Model		FM513VZ
Applicable screws (※1, ※2)	Category	Machine screw, Tapping screw
	Nom Dia.	2~5mm
	Length	Max.18mm
Tightening torque (※3)		0.3~3.8N·m
Driver		KX driver, [NX driver]
Tightening stroke		50, 100, 150, [200, 250]mm
Screw holding system		Vacuum type
Error detection	Faulty torque (faulty screw tightening)	
	Low screw in screw feeder	
	Faulty screw height (z-axis encoder pulse)(※4)	
Working air supply		0.4~0.5MPa
Power supply (Tool Unit, Screw Feeder)		Single phase 200-230VAC 50/60Hz, [Single phase 100-115VAC 50/60Hz]
Tool unit weight(※5)		Approx. 7.0kg
Screw feeder		FF311DR/FF503H
Controller		RC77-T1/RC75-T1

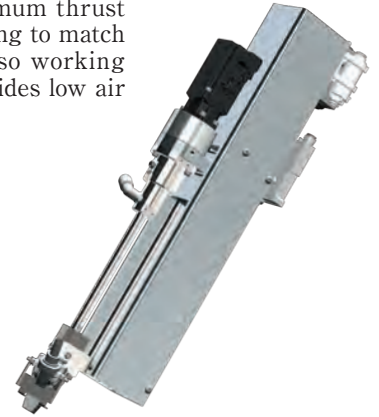

- ※1) Products will be built up based on specification of screws, therefore it can be used for one kind of screws only.
- ※2) Application range of screws will be changed by type of screw head, or size. Please contact us to make sure for it.
- ※3) The type of driver varies depending on target torque.
- ※4) It can be detected more than 2mm the faulty screw height. And also another high accuracy type of sensor is available to mount in option.
- ※5) It's a mass (weight) when the stroke is 100mm, and it isn't include the feeder and controller.

Specifications of controller

[] : Optional

Model	RC77-T1	RC75-T1
Supply voltage	Single phase 200-230VAC 50/60Hz, [Single phase 100-115VAC 50/60Hz]	
Robot movement	PTP, Semi-closed loop control	
Position feedback	Incremental value encoder system	
Communication port for operation panel	Ethernet	RS-422
Memory	Memory backup	Flash memory backup
External input (※1, ※2)	Standard user port, 16 points. [Additional 32 external points available]	
External output (※1, ※2)	Standard user port, 16 points. [Additional 32 external points available]	
Field network	Ethernet, EtherNet/IP™, [CC-Link, DeviceNet™]	[CC-Link]
Teaching method	MDI, Remote teaching, Direct teaching	
Point control	Max.: 1,000 points	
PLC program	Ladder diagram steps is 1500k which is include 26k steps for system	Ladder diagram steps is 16k which is include 13k steps for system
Outside dimensions(W×H×D)	200×210×325mm	170×210×270mm
Weight	Approx. 8.0kg	Approx. 6.5kg
Operation panel	[Handy type touch panel (with Emergency switch and Dead-man's switch)], Pendant can be used as manual control panel Connection cable: RC77(4.5m), RC75(3m)	
PC software	[KV STUDIO (Ver10.01 or later)](※3)	[GX Developer or GX Works (Ver.2 or later)](※4)

- ※1) External input/output may be used as a screw-driving system depending on the device configuration.
- ※2) PNP type also available. (Need to specify at order timing, NPN or PNP.)
- ※3) KV STUDIO is a product by KEYENCE.
- ※4) GX Developer and GX Works are products of Mitsubishi Electric.

Thrust control function

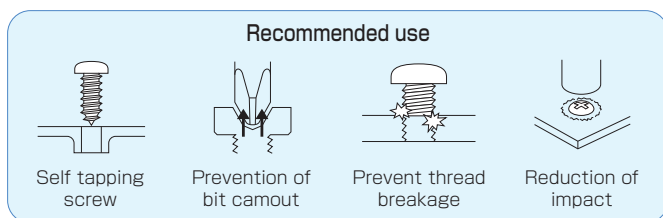
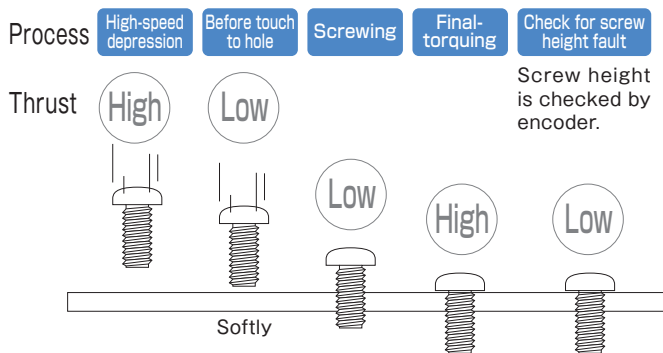

Tool unit outside dimension drawing Unit:mm

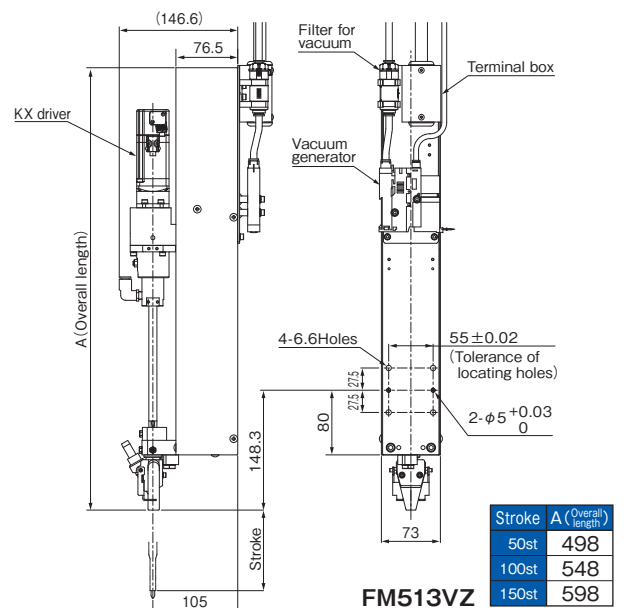

Feature

Screws are held in the screw guide by air suction. This type is highly versatile, making it perfect for tightening in narrow spaces, countersunk holes, and uneven surfaces.

Specifications of tool unit

[] : Optional

Model		FM312V	FM513V	FM810V-01	FM810V-02
Applicable screws (※1, ※2)	Category	Machine screw, Tapping screw			Hexagon bolt
	Nom Dia.	1.7~3mm	2~5mm	5~8mm	
	Length	Max, 10mm	Max, 18mm	Max, 30mm	
Tightening torque(※3)		0.1~1.5N·m	0.3~3.8N·m	4~22N·m	
Driver		KX driver, [NX driver]			
Tightening stroke		50, [75, 100]mm	50, 100, 150, [200, 250]mm	100, 150, 200, [250]mm	100, 150, 200mm
Screw holding system		Screw guide vacuum type			Bit vacuum type
Error detection		Faulty torque (faulty screw tightening)			
		Low screw (in screw feeder)		Low screw (in screw feeder)	
		Faulty screw height (Photoelectric sensor)(※4)		[Faulty screw height (proximity sensor)](※4)	
Working air supply		Clean air from 0.4 to 0.5 MPa			
Power supply (Tool Unit, Screw Feeder)		Single phase 200-230VAC 50/60Hz, [Single phase 100-115VAC 50/60Hz]		Single phase 200VAC 50 or 60Hz, [others than 200VAC]	
Tool unit weight(※5)		Approx. 5.0kg	Approx. 6.0kg	Approx. 14.0kg	Approx. 15.5kg
Screw feeder		FF311DR/FF503H		FF801H	
Controller		SD75-T1			

※1) Products will be built up based on specification of screws, therefore it can be used for one kind of screws only. ※2) Application range of screws will be changed by type of screw head, or size. Please contact us to make sure for it. ※3) The type of driver varies depending on target torque. ※4) It can be detected more than 2mm the faulty screw height. And also another high accuracy type of sensor is available to mount in option. ※5) It's a mass when the stroke is 100mm, however it be 50mm stroke for FM312V, and these aren't include the feeder and controller.

Specifications of controller

[] : Optional

Model	SD75-T1
Supply voltage	Single phase 200-230VAC 50/60Hz, [Single phase 100-115VAC 50/60Hz]
Communication port for operation panel	RS-422
Memory	EEPROM
External output (※1, ※2)	Standard user port, 2-pos. [I/O addition possible]
External output (※1, ※2)	Standard user port, 4-pos. [I/O addition possible]
Field network	[CC-Link]
PLC program	25K steps (including 5K steps used for the system)
Outside dimensions (W×H×D)	110×210×270mm
Weight	Approx. 3.0kg
Operation panel	[Handy type touch panel] Connection cable:3m
PC software	[GX Developer or GX Works (Ver.2 or later)](※3)

※1) External input/output may be used as a screw-driving system depending on the device configuration.
 ※2) PNP type also available. (Need to specify at order timing. NPN or PNP.)
 ※3) GX Developer and GX Works are products of Mitsubishi Electric.



Tool unit outside dimension drawing Unit:mm

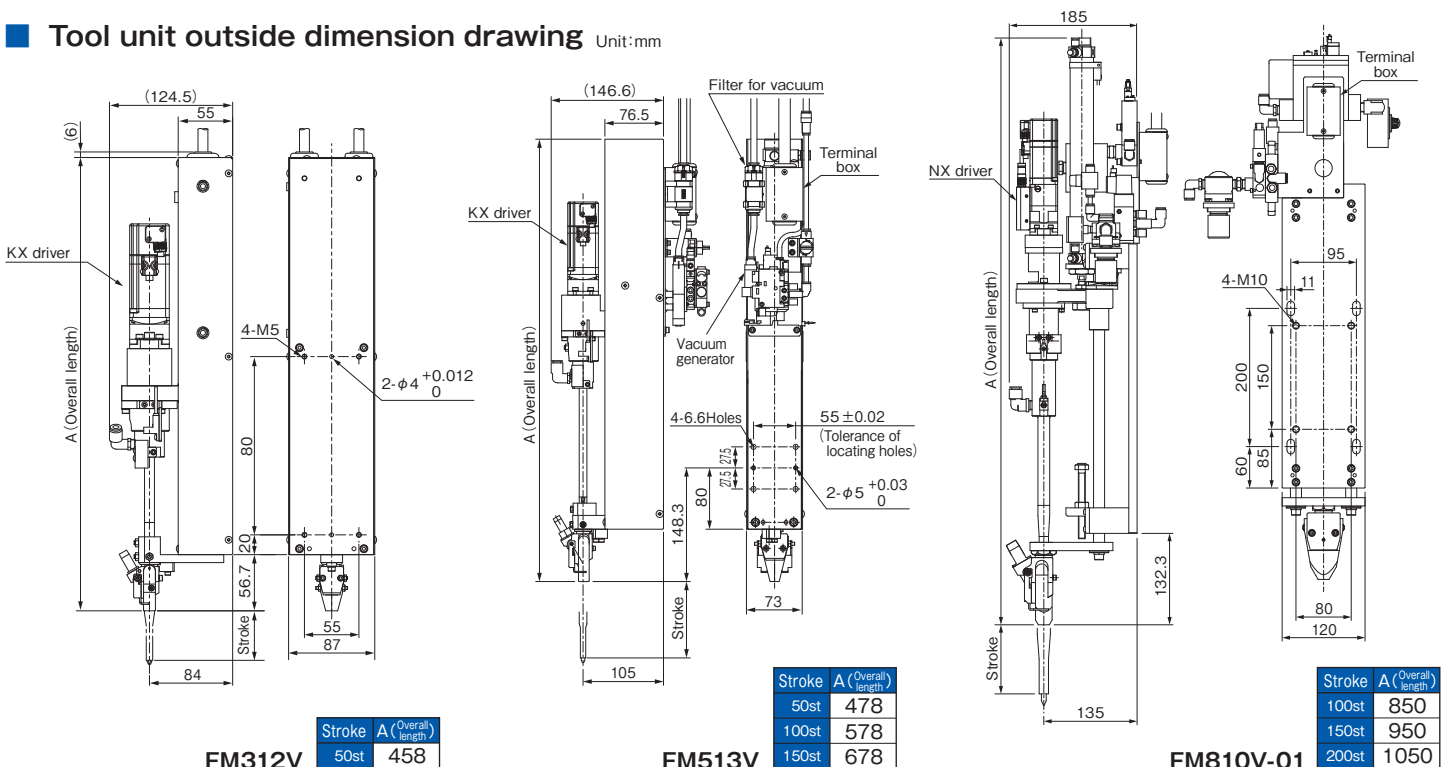

Feature

Screws are held mechanically. This type features a simple and low-cost structure. It is perfect for flat workpieces with no uneven surfaces or obstructions.

Specifications of tool unit

[] : Optional

Model		FM510C	FM810C-01	FM810C-02
Applicable screws (※1, ※2)	Category	Machine screw, Tapping screw		Hexagon bolt
	Nom Dia.	2~5mm		5~8mm
	Length	Max.20, [25]mm		Max.30, [40]mm
Tightening torque(※3)		0.3~4N·m		4~22N·m
Driver		KX driver, [NX driver]		
Tightening stroke		50, 100, [150]mm		100, 150, 200mm
Screw holding system		Chuck type		
Error detection		Faulty torque (faulty screw tightening)		
		Low screw (in screw feeder)	Low screw (in screw feeder)	
		[Faulty screw height (proximity sensor)](※4)		
Working air supply		Clean air from 0.4 to 0.5 MPa		
Power supply (Tool Unit, Screw Feeder)		Single phase 200-230VAC 50/60Hz, [Single phase 100-115VAC 50/60Hz]		Single phase 200VAC 50 or 60Hz, [others than 200VAC]
Tool unit weight(※5)		Approx. 4.5kg		Approx. 15.5kg
Screw feeder		FF311DR/FF503H		FF801H
Controller		SD75-T1		

※1) Products will be built up based on specification of screws, therefore it can be used for one kind of screws only. ※2) Application range of screws will be changed by type of screw head, or size. Please contact us to make sure for it. ※3) The type of driver varies depending on target torque. ※4) It can be detected more than 2mm the faulty screw height. ※5) It's a mass (weight) when the stroke is 100mm, and it isn't include the feeder and controller.

Specifications of controller

[] : Optional

Model	SD75-T1
Supply voltage	Single phase 200-230VAC 50/60Hz, [Single phase 100-115VAC 50/60Hz]
Communication port for operation panel	RS-422
Memory	EEPROM
External output (※1, ※2)	Standard user port, 2-pos. [I/O addition possible]
External output (※1, ※2)	Standard user port, 4-pos. [I/O addition possible]
Field network	[CC-Link]
PLC program	25K steps (including 5K steps used for the system)
Outside dimensions (W×H×D)	110×210×270mm
Weight	Approx. 3.0kg
Operation panel	[Handy type touch panel] Connection cable: 3m
PC software	[GX Developer or GX Works (Ver.2 or later)](※3)

※1) External input/output may be used as a screw-driving system depending on the device configuration.
 ※2) PNP type also available. (Need to specify at order timing. NPN or PNP.)
 ※3) GX Developer and GX Works are products of Mitsubishi Electric.

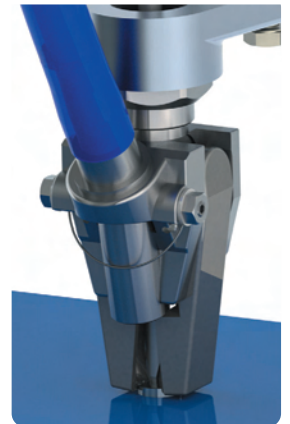

Tool unit outside dimension drawing Unit:mm

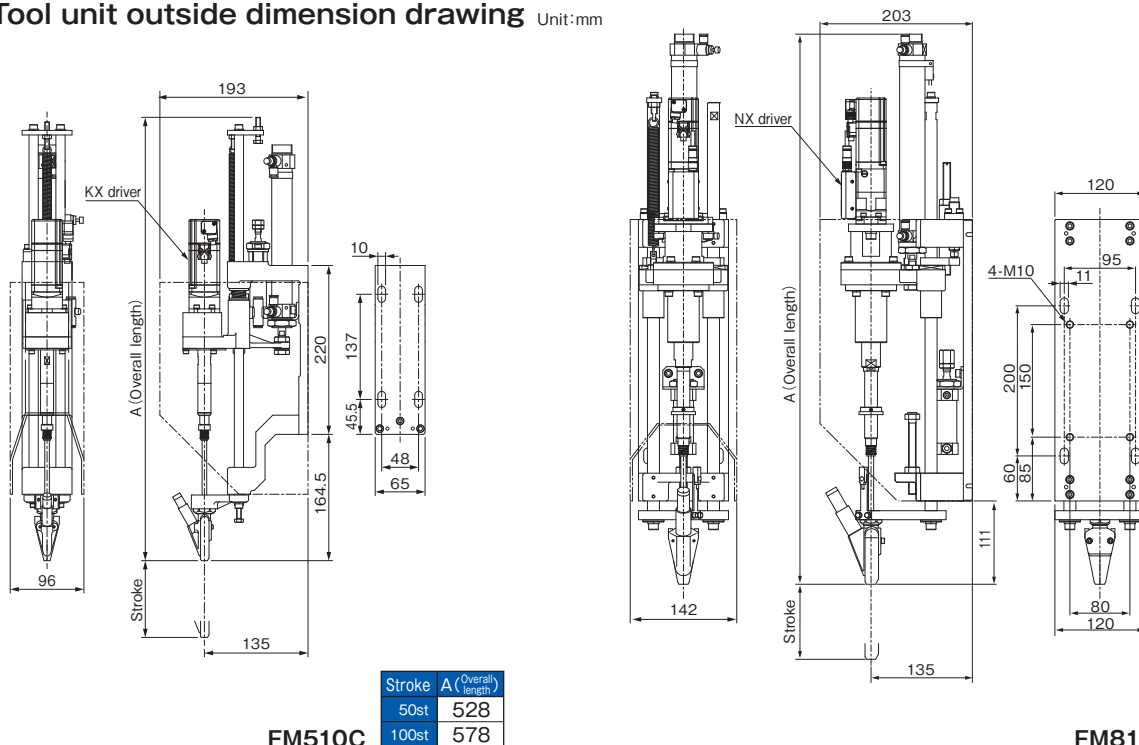

FM510C

FM810C-01

Device configuration (FM513VZ)

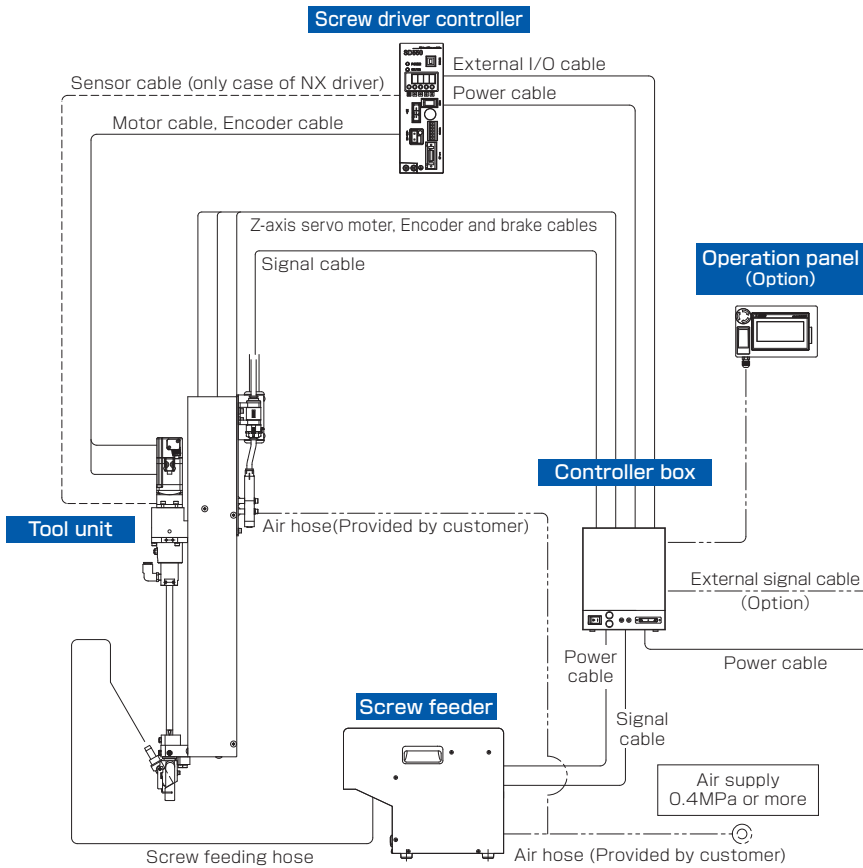

Standard length of cable

Layout	Length
Tool unit ⇄ Screw driver controller	4m
Tool unit ⇄ Control box	4m
Control box ⇄ Screw feeder	3m
Control box ⇄ Screw driver controller	4m
Screw feeder ⇄ Tool unit	3m

Exempl of machine configuration for FM513V

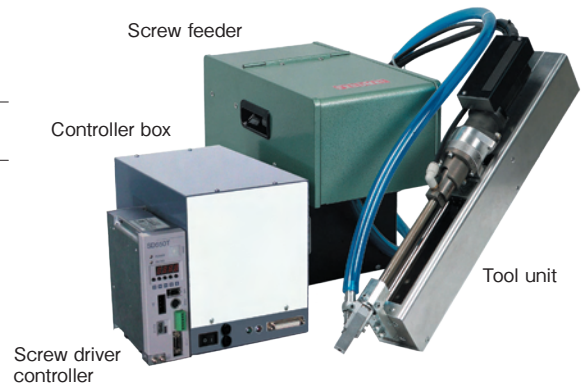

The device in the photo is an example of the configuration

Usage example

It's possible to mount for Yθ (linear & swivel) type and XY (cartesian) type, also articulated robot by other company.

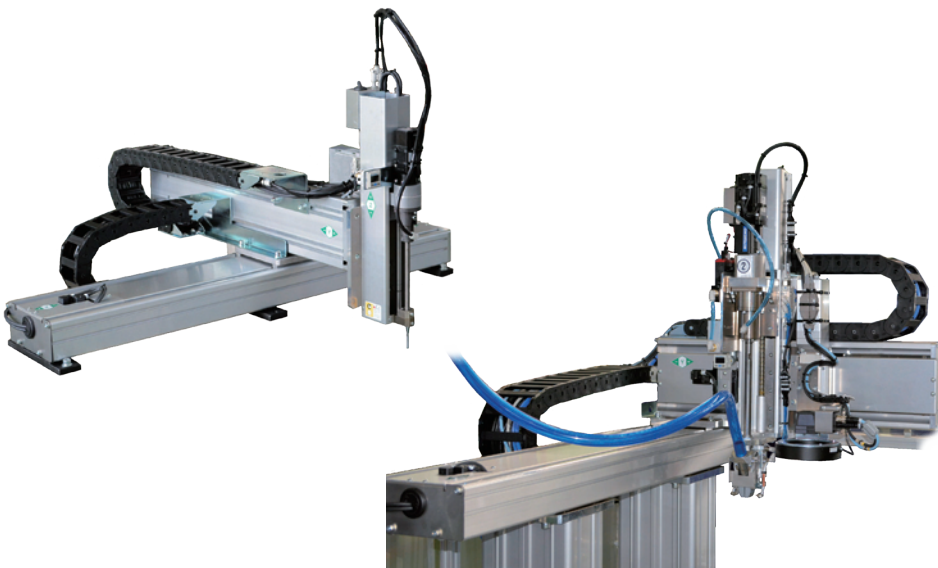

Case of XY (cartesian) robot



Case of Yθ (linear & swivel) robot

※For more information, see our website or contact the nearest sales office

For introduction movie, go into here



NITTOSEIKO CO.,LTD.

Assembly Machine Division / Shiroyama Plant
Global Sales Section

2,Shiroyama-chou,Ayabe-city,Kyoto 623-0003,Japan
TEL:+81-773-42-1290 FAX:+81-773-45-3680
URL:<https://www.nittoseiko.co.jp/>

●Specifications and other matters are subject to modifications for performance improvements without notice.
●Unique nouns like the product name indicated in this brochure are registered or not registered trademark of each company.
●EtherNet/IP™ is a trademark of ODVA.
●DeviceNet™ is a trademark of ODVA.

TM100322